

TOMCAT[®]

FULL LINE CATALOG

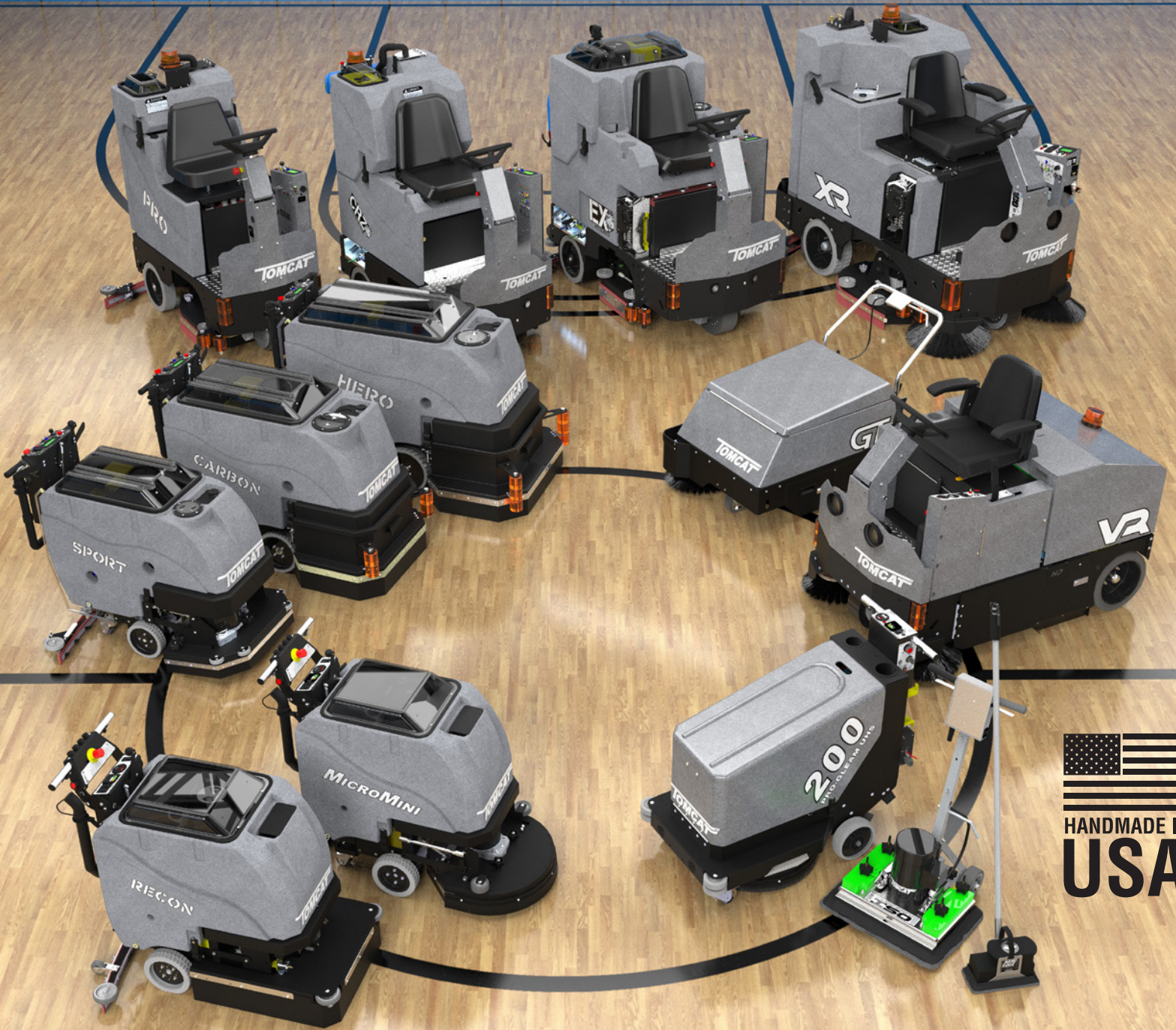

HANDMADE IN
USA

Free Demonstration At Your Facility!

800-450-9824

(+001)-262-681-6470

www.tomcatequip.com



HANDMADE TOUGH IN USA

Since 1986, our family owned company has been designing, building and supporting the best in floor maintenance equipment. Our **TOMCAT** brand, services the world with unsurpassed commercial cleaning equipment, continually exceeding expectations, and setting the industry bar that much higher. We've built our reputation by providing the highest value machines and local support via 425 distributors in over 42 different countries.

THREE SCRUB SYSTEMS TO CHOOSE FROM

Corner Rollers
Non-Marking

HD Motor
Better Performance

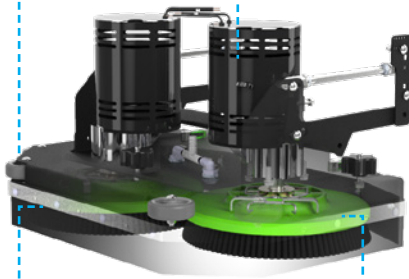

Removable Shroud
Protects Deck

Thick Steel Design
7-10g Thick for Durability

Disk Benefits

- Brush / Pad Selection
- Lowest Maintenance Cost
- Gimballed Drivers Improves Cleaning On Irregular Floors
- Brushes Individually Driven For Unmatched Performance

Corner Rollers
Non-Marking

HD Motors
Better Performance



Oversized Brushes (6")
Longer Life

Thick Steel Design
7-10g Thick for Durability

Cylindrical Benefits

- Eliminates Dust Mopping
- Scrub & Sweep Simultaneously
- Superior Tile & Grout Cleaning

Corner Rollers
Non-Marking

HD Motor
Better Performance

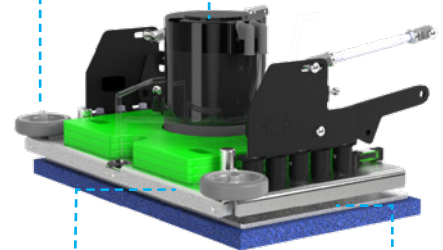

Oversized Isolators (5/16")
Long Life - 1,000 Hours

Solid Aluminum Plate
7-10g Thick for Durability

EDGE Benefits

- Chemical Free Stripping
- Reduce Slip & Fall Potential
- Earn LEED Credits
- 70% Reduction in Water Usage
- Consistent Results - No Swirl Marks
- Wet screens Wood Gym floors

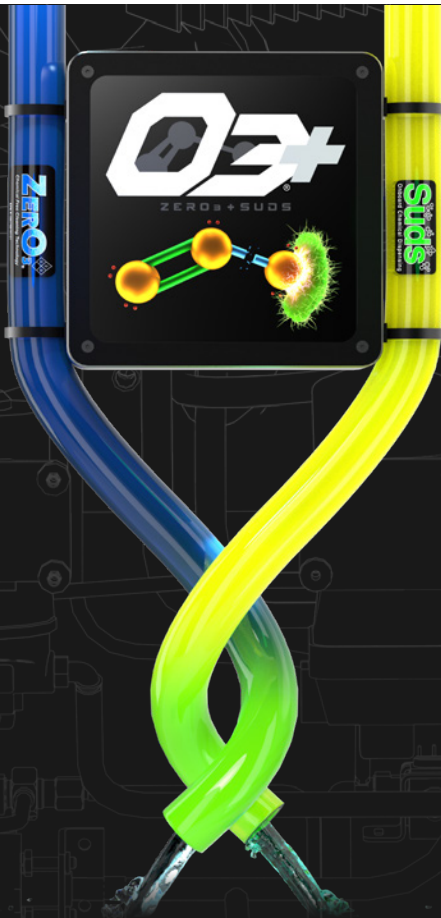

Clean Your Way - Onboard O3+®

In most applications, chemical-free cleaning results in acceptable levels of cleanliness. But, there are still applications and soil loads that require chemistry. In those cases, what do you do?

The **O3+® System** provides you two completely separate systems: ZERO³® Aqueous Ozone (AO) system and Suds Chemical Dilution system.

With the ability to immediately dispense detergent or AO at the flip of a switch, we provide a system that is desired in today's market.

-  Reduce the Cost to Clean
-  Minimize Environmental Impact
-  Improve Facility Appearance
-  Easy Operation & Safe Handling of Chemicals

WALK BEHIND SCRUBBERS

The **TOMCAT** walk-behind scrubbers bring renowned toughness into the walk-behind auto scrubber market. Their compact length allows the battery scrubbers to maneuver into congested areas and their unique design keeps the scrub deck well protected. The solution and recovery tanks tip back for easy scheduled maintenance. Our thick steel frames and heavy duty components keep **TOMCAT** scrubbers working long after others have been discarded.



RECON

MICROMINI

SPORT

CARBON

HERO

Disk Scrub Path:

17" & 20"
(43.2 & 51 cm)

17" & 20"
(43.2 & 51 cm)

17", 20", & 26"
(43.2, 51 & 66 cm)

26" & 28"
(66 & 71.1 cm)

30" & 34"
(76.2 & 86.4 cm)

Cylindrical Path:

N / A

N / A

25"
(63.5 cm)

25" & 29"
(63.5 & 73.7 cm)

29" & 33"
(73.7 & 83.8 cm)

EDGE Path:

N / A

20" & 24"
(51 & 61 cm)

20" & 24"
(51 & 61 cm)

24" & 28"
(61 & 71.1 cm)

28" & 32"
(71.1 & 81.3 cm)

Dimensions (LxWxH):

35" x 18" x 38"
(88.9 x 45.7 x 96.5 cm)

42" x 21" x 39"
(106.7 x 53.3 x 99.1 cm)

45" x 21" x 39"
(114.3 x 53.3 x 99.1 cm)

52" x 22" x 40"
(132.1 x 55.9 x 101.6 cm)

55" x 26" x 40"
(132.1 x 66 x 101.6 cm)

Solution / Recovery Tank:

10 Gal / 10 Gal
(37.6 / 37.6 liters)

10 Gal / 10 Gal
(37.6 / 37.6 liters)

13 Gal / 15 Gal
(49.2 / 56.8 liters)

21 Gal / 23 Gal
(79.5 / 87 liters)

35 Gal / 37 Gal
(132.5 / 140.1 liters)

Run Time:

Up to 2.5 Hours*

Up to 3.5 Hours*

Up to 2.5 Hours*

Up to 3.5 Hours*

Up to 5.0 Hours*

Theoretical Coverage:

Up to 15,748 sqft/hr
(1,436 sqm/hr)

Up to 15,748 sqft/hr
(1,436 sqm/hr)

Up to 27,027 sqft/hr
(2,510.9 sqm/hr)

Up to 27,027 sqft/hr
(2,510.9 sqm/hr)

Up to 31,915 sqft/hr
(2,965 sqm/hr)



Front Fill System
Operator Ergonomics for Easy Fill

Vacuum Screen Isolated
Extends Vacuum Motor Life

500 lb Actuator
Powerful Performance

Vacuum Box
Protects Vacuum Motor

HD Scrub Motors
Performance & Long Life

Marine Grade Controls
Easy Maintenance

Drain Saver Basket
Eliminates Clogged Floor Drains

Stainless Tank Baffle
Keeps Foam on "Dirty" Side

Poly Battery Box
Keeps Liquid Contained

Grey Wheels & Wall Rollers
Eliminates Skid Marks

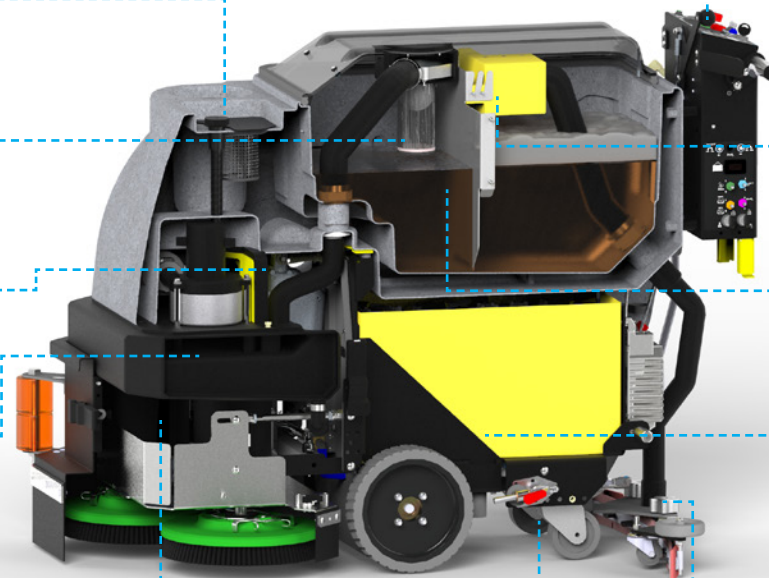

RIDE-ON SCRUBBERS

The **TOMCAT** ride-on scrubber line offers customers an ideal and affordable solution to their floor cleaning needs. The three platforms include a powerful 36-volt system and heavy duty, steel construction for the most severe environments. Adjustable steering columns are standard, as is the front, steel apron which protects the operator's feet from collision. An American Made front wheel drive system allows for U-Turns within the machine's length, and unmatched manoeuvrability. Stainless fasteners and filter screens simplify service.



	Pro	CRZ-ST / CRZ-HD	EX-ST / EX-HD	XR
Disk Scrub Path:	26" & 28" <i>(66 & 71.1 cm)</i>	26", 28", 30" & 34" <i>(66, 71.1, 76.2 & 86.4 cm)</i>	30" & 34" <i>(76.2 & 86.4 cm)</i>	34", 40" & 45" <i>(86.4, 101.6 & 114.3 cm)</i>
Cylindrical Path:	25" <i>(63.5 cm)</i>	25", 29" & 33" <i>(63.5, 73.7 & 83.8 cm)</i>	29" & 33" <i>(73.7 & 83.8 cm)</i>	34", 40" & 46" <i>(86.4, 101.6 & 116.8 cm)</i>
EDGE Path:	24" & 28" <i>(61 & 71.1 cm)</i>	28" & 32" <i>(71.1 & 81.3 cm)</i>	N / A	N / A
Dimensions (LxWxH):	48" x 24" x 55" <i>(66 x 76.2 x 86.4 cm)</i>	64" x 34" x 56" <i>(162.6 x 86.4 x 142.2 cm)</i>	62" x 32" x 57" <i>(157.5 x 81.3 x 144.8 cm)</i>	69" x 36" x 56" <i>(175.3 x 91.4 x 142.2 cm)</i>
Solution / Recovery Tank:	22 Gal / 23 Gal <i>(83.3 / 87.1 liters)</i>	33 Gal / 36 Gal <i>(124.9 / 136.3 liters)</i>	46 Gal / 49 Gal <i>(174.1 / 185.5 liters)</i>	65 Gal / 78 Gal <i>(246.1 / 295.3 liters)</i>
Run Time:	Up to 4 Hours*	Up to 4.5 Hours*	Up to 5 Hours*	Up to 5 Hours*
Theoretical Coverage:	Up to 26,745 sqft/hr <i>(2,484.7 sqm/hr)</i>	Up to 44,118 sqft/hr <i>(4,099.0 sqm/hr)</i>	Up to 46,643 sqft/hr <i>(4,333.3 sqm/hr)</i>	Up to 46,643 sqft/hr <i>(4,333.3 sqm/hr)</i>



Drain Saver Basket
Protect Your Drains

Vacuum Screen
Vacuum Motor Protection

Tip Back Tanks
Operator Ease for Draining

Vacuum Protection
& Muffler System

Service Cabinet
Single Point Service Location

Flip-up Bumper
Steel Bumper for Protection

HD Tires
Solid Tire Promotes Long Life



Dual Cup Holders
Operator Benefit

Indicator Dash Lights
Operator Ease

Heavy Duty Front Apron
Operator Foot Protection

Onboard Charger
Optional for CE or CEC certifications

Steel Frame
HD Frame for Long Life

Non-Marking Rollers
Machine Protection

FLOOR MACHINES

TOMCAT'S EDGE series of surface preparation equipment gives operators the ability to remove multiple layers of finish without using chemicals, work with a variety of quality pads, and prep and refinish a classroom up to six times faster. Our unique oscillating heads don't fling water away from the cleaning area, so 70% less water / soap is required to clean - increasing operator productivity. Help the environment while saving money and just use water to remove floor finish. The **EDGE** system combined with our maroon "Prep Pad" prepares a floor for quick and easy re-coat.



NANO EDGE



EDGE ISO 20"

Cleaning Path:

10.5"
(26.7 cm)

20"
(50.8 cm)

Pad Dimensions:

10.5" x 5.25"
(26.7 x 13.3 cm)

20" x 14"
(50.8 x 35.6 cm)

Motor Power:

0.33 HP
(246.1 watts)

1.5 HP
(1118.6 watts)

RPM 120 VAC / 60 Hz (220 VAC / 50 Hz):

4,100 RPM (3,400 RPM)

3,450 RPM (2,850 RPM)

Material:

Steel Head

Stainless Steel

Weight:

22 lbs
(10 kg)

144 lbs (up to 232 lbs)
(65.3 kg [up to 105.2 kg])

Productivity:

N / A

Up to 5,000 sqft/hr
(464.5 sqm/hr)

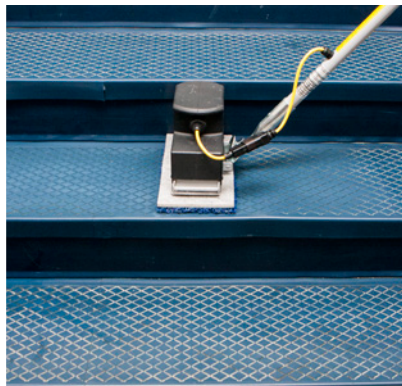

Pivoting Handlebar & Wheels
Operator Ergonomics

Slotted Removable Weights
Easy Removal for Multiple Applications

Stainless Deck
Eliminates Corrosion

1/4" Thick Aluminium Plate
Machine Durability

Heavy Duty Motor
American Made

10x Isolation
Protects Operator's Hands

1,000 Hour Rated Isolators
Long Lasting

Optional Solution System
Solution Wherever You Need It

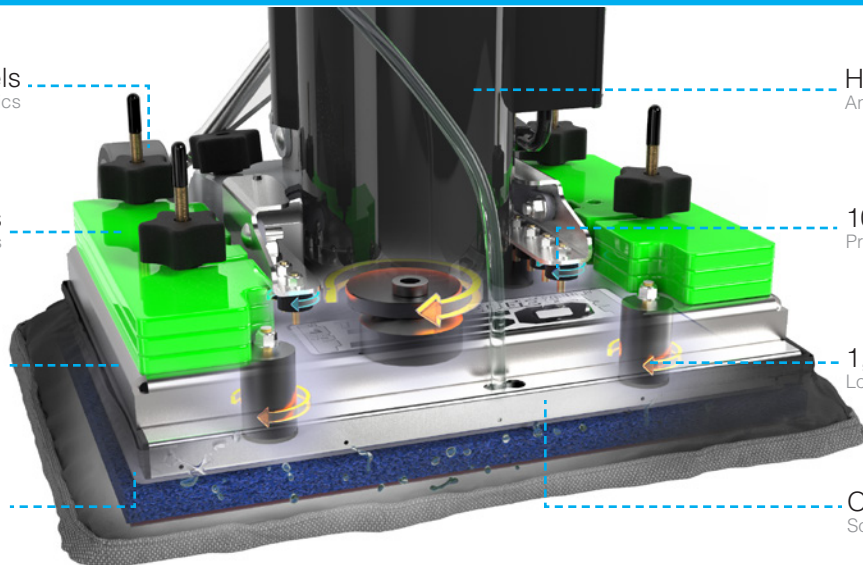

BURNISHERS

TOMCAT Burnishers bring propane quality shine and productivity to the battery market. Each unit is fabricated from heavy duty steel and quality domestic components. The fully floating head is allowed to follow the contours of the floor and the HD motor offers optimum shine at an operational speed. Dust control is a standard feature, which eliminates the need to dust mop afterwards.



200 UHS



270 UHS

Burnish Path:

20"
(51 cm)

27"
(68.6 cm)

Motor Power:

3.0 HP
(2,237.1 watts)

3.0 HP
(2,237.1 watts)

Pad Speed:

2,000 RPM

1,600 RPM

Dimensions (LxWxH):

54" x 25" x 50"
(137.2 x 63.5 x 127 cm)

54" x 25" x 50"
(137.2 x 63.5 x 127 cm)

Run Time:

Up to 3 Hours*

Up to 3 Hours*

Theoretical Coverage:

Up to 16,200 sqft/hr
(1,505 sqm/hr)

Up to 22,059 sqft/hr
(2,049.3 sqm/hr)



Optional Onboard Charger
Charge Anywhere

Non-marking tires
HD Solid

Pad Adjustment
Easily Change Pressure

Dust Filter
Collects Dust

Balanced Deck Shroud
Follows Wavy Floors



Stainless Handlebar
Easy Grip

Extend Run Time 25%
Optional HD Batteries

Poly Hood Opens Completely
Ease Of Maintenance

Corner Bumpers
Protect your Environment

Fresh Air Intake
Extends Motor Life

SWEEPERS

TOMCAT sweepers are built to clean carpeting, artificial turf, tennis courts, and warehouses. Our sweepers pick up lint, wood chips, sand and dust in a single pass. These are some of the toughest sweepers on the market, and the steel construction keep them working for years to come. The brooms adjust automatically to floor levels while the unique filter has unmatched dust capacity and typically lasts the life of the machine.



GT

VR

Sweep Path:

34"
(86.4 cm)

46"
(116.8 cm)

Main Broom:

26" x 10"
(66 x 25 cm)

32" x 10"
(81.3 x 25 cm)

Hopper Capacity:

2 cubic feet
(56.6 liters)

4 cubic feet
(113.3 liters)

Dimensions (LxWxH):

58" x 31" x 38"
(147.3 x 78.7 x 96.5 cm)

64" x 37" x 55"
(162.6 x 94 x 139.7 cm)

Run Time:

Up to 4 Hours*

Up to 7 Hours*

Theoretical Coverage:

Up to 30,000 sqft/hr
(2,787.1 sqm/hr)

Up to 60,000 sqft/hr
(5,574.2 sqm/hr)



Self Propelled
Operator Ease

Stainless Handlebar
Fully Adjustable

10" Diameter Main Broom
Reduces Maintenance

1/2 Ton Capacity Tire
Improved Manoeuvrability

Self Adjusting Main Belts
Reduces Down Time

Oversized Battery
Extends Run time

Onboard Charger
Permits Remote Charging

Baghouse Filter
High Capacity & Long Life

900 LB. Capacity Caster
Improved Manoeuvrability

Large/Powerful Side Broom
Increases Productivity

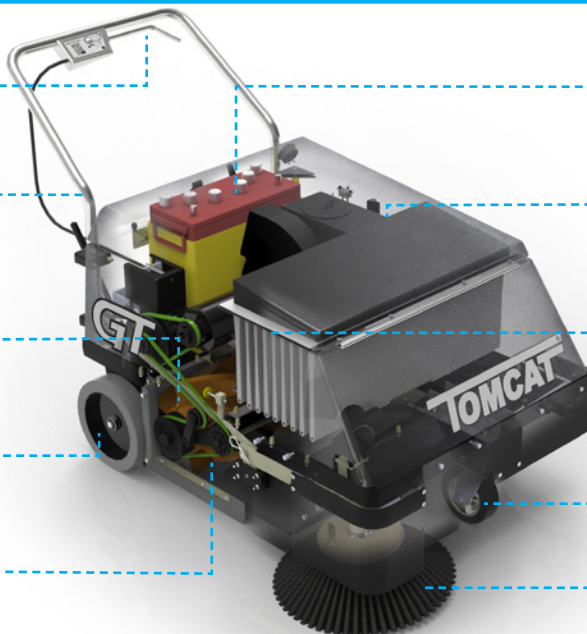

BUILT-IN PROTECTION

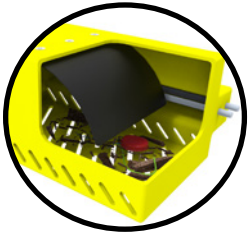

The Drain Saver Basket collects debris so it doesn't clog floor drains.

Water from rear squeegee travels through this hose into the recovery tank.

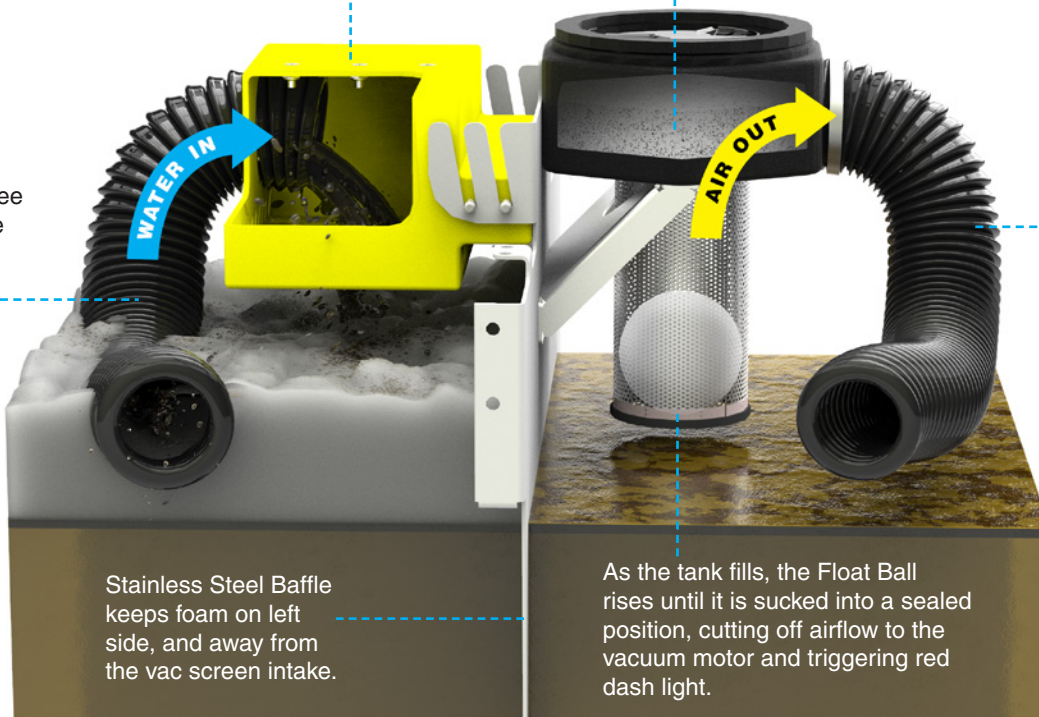

White Filter captures fine particulate.

Airflow is drawn through this hose. Any water from this point will travel to the Yellow Vac Box.

Stainless Steel Baffle keeps foam on left side, and away from the vac screen intake.

As the tank fills, the Float Ball rises until it is sucked into a sealed position, cutting off airflow to the vacuum motor and triggering red dash light.

AUTHORIZED DISTRIBUTOR



APPLICATIONS

School Systems

Healthcare

Warehouses

Grocery Stores

Retail

Automotive

Food Packaging

Airports

Sports Arenas

Manufactured By:
 R.P.S. Corporation
 1711 South Street
 Racine, Wisconsin 53404 (USA)
 Phone: (800) 450-9824
 International: (+001) 262-681-6470
www.tomcatequip.com

Copyright R.P.S. Corporation 2018. All rights reserved. Since our policy is one of constant improvement, all specifications are subject to change without notice.